

Spectra Watermakers  
MPC-3000 Field Technical Manual  
Revision A25 04-02-04



This Manual is intended for use by Spectra Watermakers Field Service Technicians as a technical reference document. Its goal is to contain the necessary information as to be of value to field technicians addressing installation of hardware and software, system configuration, and system troubleshooting. In the event that necessary information is not contained in this document, call Spectra Watermakers at (415) 526-2780.

**Table of Contents:**

- 3) Software Installation
- 3) Software Features
- 6) Computer Settings
- 7) Rotor Flow Meter Operation
- 8) Salinity Probe Calibration
- 9) PPM Conversion Chart
- 10) Upgrade Procedures
- 11) A19 Software Notes
- 12) Spectra.ini
- 14) Tank Switch Operation
- 15) MPC-3000 Operation Guide

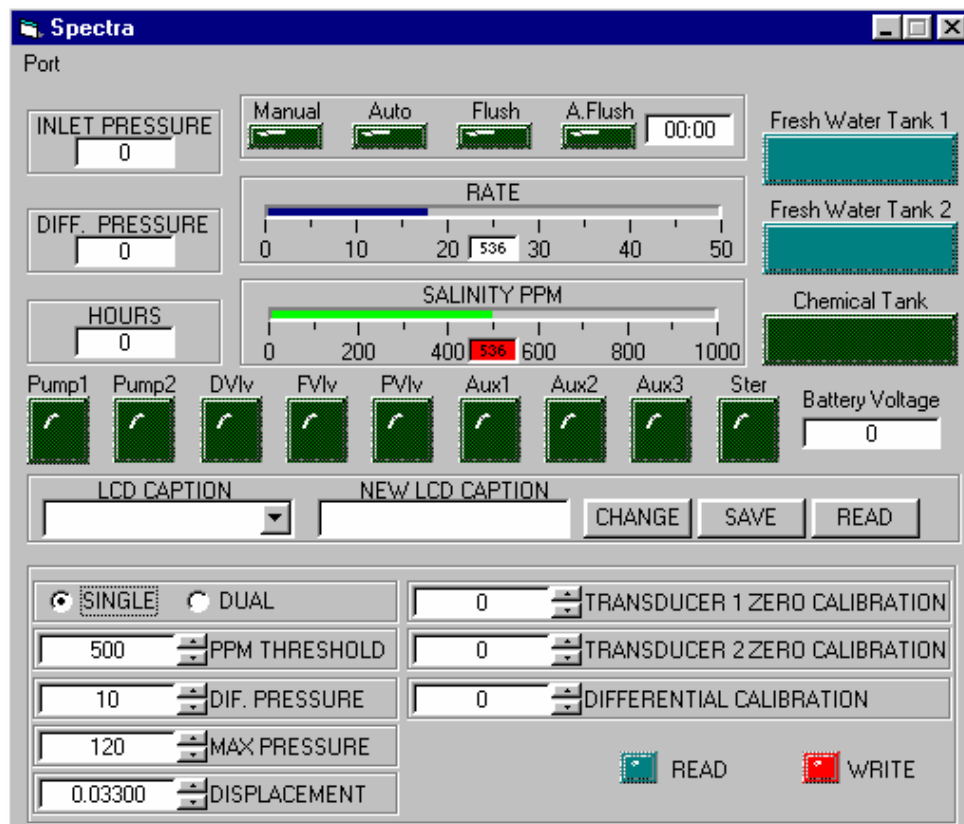

## Software Installation:

- 1) Insert the Spectra Watermakers CD-ROM into the computer's CD-ROM drive.
- 2) Using "My Computer" or Windows Explorer, locate and double-click the "setup.exe" file on the CD-ROM drive. This will begin the installation process. Follow the on-screen instructions.
- 3) Before using the software, your MPC-3000 circuit board must be connected to your computers' COM port using a standard RS-232 serial cable (NO Crossovers on cable) : 12v or 24v DC power must be applied to the MPC-3000 board- the board must be "on" before the software can communicate with it. The software may not run if these steps are not taken. You will get an error message if there is a com port conflict.
- 4) Once the software has been installed, open the directory where it was installed to, locate and double-click the "spectra.exe" file to run the program.
- 5) If you have no serial port available you may purchase an adapter from USB to serial port.

To reset the COM port right click on the software icon. Go to the properties menu and right click. Next, click find target, Go to and open the "spectra. Ini" file. The top number of the two in the notebook utility is the port number. This can be changed and saved as you exit the utility.

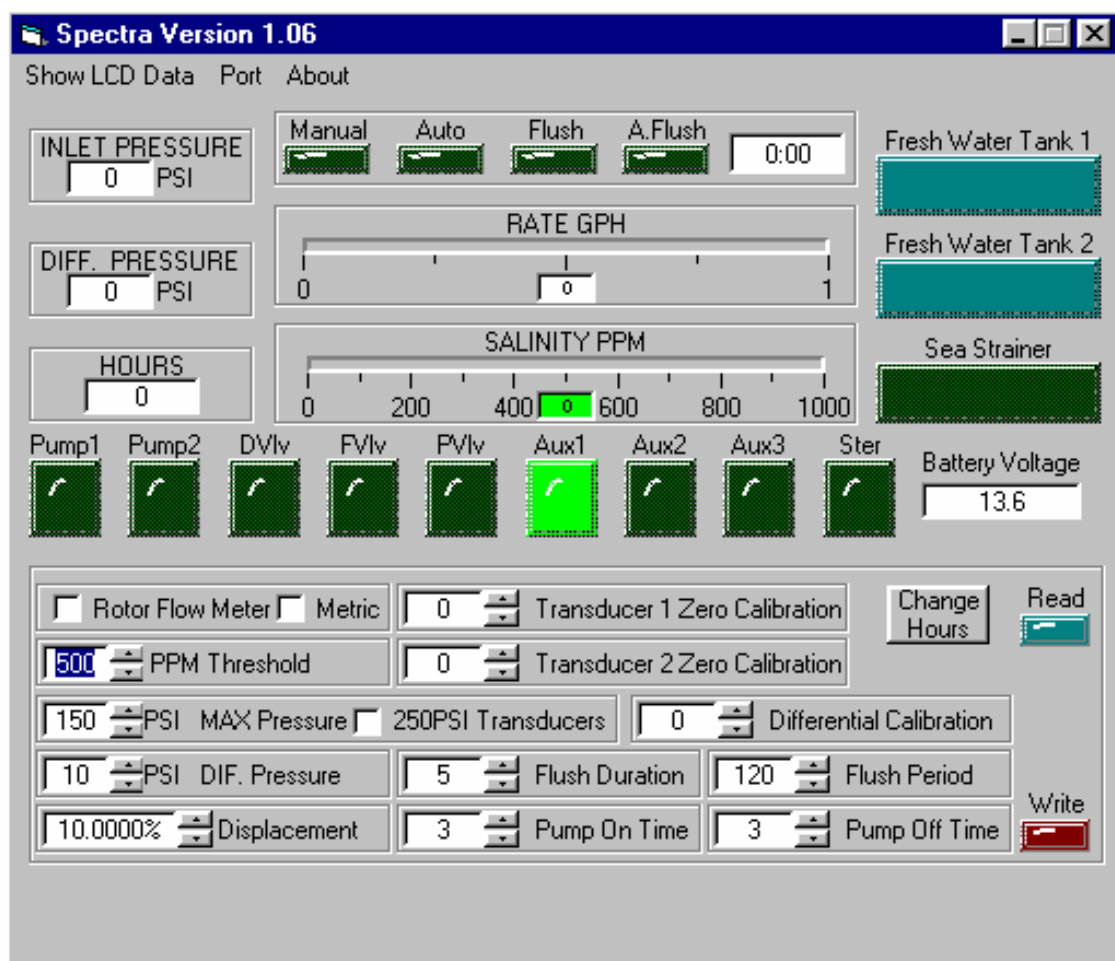

## Software Features:

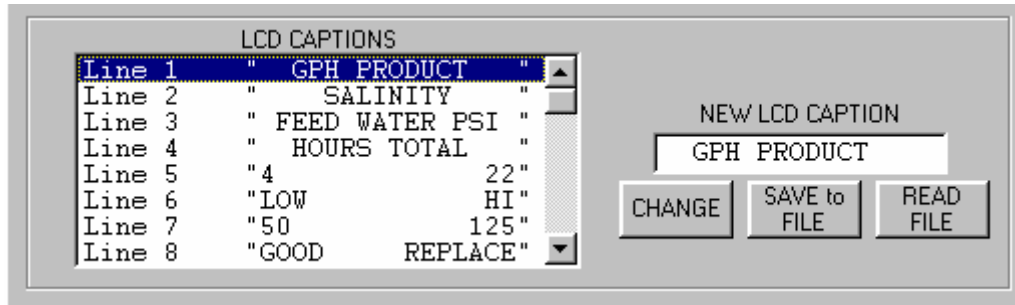

- 1) **Show LCD Data:** Clicking on this field will change the settings window to allow you to change what is displayed on the LCD. Select the line to change, enter a new caption for that line, and hit change. This feature can allow you to customize the display for another language if desired. There are limits to how many characters are allowed.
- 2) **Port:** Allows you to select which COM port on your computer will communicate with the MPC-3000 board via RS-232 serial cable.
- 3) **Inlet Pressure:** Displays real-time system pressure at the prefilters.
- 4) **Diff Pressure:** Displays real-time pressure difference between the two prefilters.
- 5) **Hours:** Displays total hours the MPC-3000 has been run.
- 6) **Manual, Auto, Flush, A.Flush, Timer:** These are simply display lights to show which mode the MPC-3000 is currently in. The timer will display any countdown time for the current mode.
- 7) **Rate GPH:** Real-time meter showing gallon-per-hour product.
- 8) **Salinity:** Real-time meter showing salinity measurement of product water in parts-per-million.
- 9) **Fresh Water Tank 1, Fresh Water Tank 2, Sea Strainer:** Display lights to indicate state of tank switches and sea strainer condition.
- 10) **Pump1, Pump2, Dvly, Fvly, Pvly, Aux1, Aux2, Aux3, Ster:** Display lights to indicate output states of the MPC board.
- 11) **Battery Voltage:** Displays current DC voltage applied to the MPC board.
- 12) **Rotor Flow Meter:** Check this box if a rotor flow meter is to be used. Refer to "Rotor Flow Meter Operation" section later in this manual.
- 13) **Metric:** Check box to change display units of measurement from english to metric. (Can also be accomplished by pressing and holding "alarm/disp" on the LCD display for 5 seconds.)
- 14) **PPM Threshold:** Default at 500ppm, sets the reject salinity level of product water. This is currently factory set at 700 PPM. (Above 700ppm is rejected, below 700ppm is accepted and diverted to holding tank).

- 15) **PSI Max Pressure:** Used to set the maximum allowable system pressure, measured at prefilters. Typically 150psi for Newport400 systems, and 250psi for Monterey/1000 gallon systems.
- 16) **PSI DIF. Pressure:** Used to set the differential cutoff pressure; the two pressure sensors at the prefilter are used to measure any difference in pressure between the two prefilters, possibly caused by a dirty filter. Differential Cutoff will stop system and sound alarm if differential pressure exceeds set maximum. Typically set to 10 psi.
- 17) **Displacement:** A percentage value that matches the percentage value of the clark pump being used. Equivalent to the size of the rod inside the clark pump; if, for example, you were using a 10% pump, then 10% of all water entering the clark pump would be “displaced”, or squeezed through the membrane into product water. Since the size of the rod is known, we can now use the stroke sensor to count the cycles of the clark pump, and get an accurate reading of GPH product output.
- 18) **Transducer 1 & 2 Zero Calibration:** Used to calibrate the pressure transducers if necessary.
- 19) **250 PSI Transducers:** Originally meant as a display light rather than a check box, this field is not normally used or necessary. Use PSI MAX Pressure instead.
- 20) **Differential Calibration:** Used in the event that a differential pressure is noticed, perhaps even at zero pressure, yet the pressure transducers appear to be in calibration, differential calibration can be used to offset the reading and resume a correct zero state.
- 21) **Flush Duration:** In minutes, the time it will take to complete one flush cycle. Typically 5 minutes, or longer for systems with long membranes or more elaborate systems.
- 22) **Flush Period:** In hours, the period of time between flushes, while in unattended storage mode. Typically 120 hours. (5 days)
- 23) **Pump On/Off Time:** In seconds, the amount of time the pump will be turned on or off during a fresh water flush mode. Meant to give the charcoal filter time to deal with the onrush of water, some systems will have the pump off time set to 0, effectively turning the pump continuously on during fresh water flush. Consult the “Computer Settings” chapter later in this manual to match your specific system.
- 24) **Change Hours:** Just in case you want to roll back your odometer.
- 25) **READ and WRITE:** Any time a change is made to your settings you must WRITE it to the microprocessor. It is recommended you follow up by pressing READ to ensure your changes took place.

**Computer Settings:** These are typical computer settings for standard Spectra systems. Unless otherwise specified, all other values remain the default Newport 400 values.

**Ventura:**

Max Pressure: 125  
Displacement: 7%  
Flush Duration: 2  
Pump On Time: 3  
Pump Off Time: 0

**Catalina 300**

Max Pressure: 125  
Displacement: 10%  
Flush Duration: 5  
Pump On time: 3  
Pump off time:6

**Newport 400:** (12 and 24v DC)

Max pressure: 150  
Displacement: 10%  
Flush Duration: 6  
Pump On Time: 3  
Pump Off Time: 3

**Newport 400 AC Version:**

Max Pressure: 150  
Displacement: 10%  
Flush Duration: 6  
Pump On Time: 3  
Pump Off Time: 0

**Newport 380 Modular Kit:**

Max Pressure: 140  
Displacement: 10%  
Flush Duration: 3  
Pump On Time: 3  
Pump Off Time: 0

**Newport 700:**

Max Pressure: 200  
Displacement: 12%  
Flush Duration: 7  
Pump On Time: 3  
Pump Off Time: 0

**Newport 1000 or Monterey:**

Max Pressure: 250  
Displacement: 20%  
Flush Duration: 8  
Pump On Time: 3  
Pump Off Time: 0

### **Rotor Flow Operation**

We are currently developing our software to work with Gems brand of rotor flow meters. A rotor flow meter is a pinwheel device with a hall-effect sensor built in, that is installed in line with product water output from the RO membrane. When water passes through the meter, it spins the pinwheel; the hall-effect sensor picks up the motions of the pinwheel and sends the frequency of the spinning pinwheel to the MPC board. The MPC board then calculates, based on a 'meter constant', the gallon-per-minute output of product water, thereby eliminating the need for a stroke sensor, which is particularly useful on systems with more than one Clark pump.

There are many different sizes of rotor flow meters, each with different throughput capabilities. The meter constant is a number between 5000 and 57000 and is calculated by the following formulas:

0 to <1GPM	$N=10,000,000*(G_{max}/F_{max})$
1 to 9GPM	$N=2,000,000*(G_{max}/F_{max})$
>10GPM	$N=100,000*(G_{max}/F_{max})$

Where  $G_{max}$  is the maximum flow rate,  $F_{max}$  is the frequency at maximum flow. The final number is an approximation and can be adjusted up or down for final calibration.

Gems sells many different types of flow meters for differing throughput requirements:

<b>Body</b>	<b>Port Size</b>	<b>RFO Part#</b>	<b>High Range</b>	<b>Low Range</b>	<b>Adapter</b>
Polypropylene	.25	155421	0.5-5.0	0.1-1.0	152147
	.50	155481	4.0-20.0	1.5-12.0	151832
Brass	.25	156261	0.5-5.0	0.1-1.0	152147
	.50	156262	4.0-20.0	1.5-12.0	151832
	.75	156263	6.0-30.0	N/A	N/A
Stainless	9/16-18 J514	165071	0.5-5.0	0.1-1.0	152147
	½" NPT	165075	4.0-20.0	1.5-12.0	151832

Gems can be reached at:

Gems Sensors, Inc.  
One Cowles Road  
Plainville, CT 06062-1198

Tel 860-747-3000  
Fax 860-747-4244

<http://www.gemssensors.com>

### **Salinity Probe Calibration:**

Salinity is a measurement of TDS, total dissolved solids in liquid: these solids will conduct electricity to varying degrees. A special probe is used, with two electrical contacts in it, to determine the resistance to the flow of electricity in the liquid.

In the Spectra Watermakers systems, the salinity probe is located just before the diversion valve, at the output of the RO membrane. This way we can look at the salinity level of the product water before deciding to either reject the water or accept it and divert it into the holding tank.

The salinity level in parts-per-million can be seen either through the salinity meter in the software, or a jumper can be added to the MPC board in the 'calibrate' position, where it can then be seen on the LCD display (rather than a bar graph). After adding the jumper, it may be necessary to cycle through the different LCD displays until the display reads 'salinity.'

### **Procedure:**

1. Locate the Calibrate jumper location on the MPC-3000 Board. Jump the terminals
2. Start the system and after the salinity stabilizes, test the product water with a calibrated hand held tester.
3. Locate the MPC calibration trimmer potentiometer on the board below the salinity probe jack. Adjust until the display PPM matches the PPM reading from the hand held salinity monitor. Turning the trim pot clockwise will lower the salinity reading, and counter-clockwise will raise it.
4. Shut the system down and disconnect the jumper on the MPC board.

If a hand held meter is not available you can remove the probe and dip it into a known calibrated solution. This can be obtained from Spectra.



## **Emergency Operation**

In the event of a salinity probe failure the MPC- Control will come up with a error code "Salinity Probe Failed". This will render the control inoperative. To make the control temporarily operative you may remove the plug connector from the probe and place into a small quantity of product water. Use a nonmetallic container. Restart the system. If you receive a high salinity code you have the choice of adding some salt water to the container or adjusting the control calibration. Locate the calibration screw on the control board, which is located 3/4" below the salinity probe female plug on the MPC board. Rotate clockwise several turns.

**Note: this is a temporary repair that will destroy the probe cable. After several days in this mode you may have to remove the connector, strip and spread the wires and replace in the water.**

## Upgrades:

It is possible to upgrade Newport series watermakers through the different versions of software/firmware. Outlined below are some of the requirements and procedures necessary for upgrade.

Note that it is very important to use the correct version of software for the version of microprocessor.

**A25** Is the most current revision to date. It adds automatic pressure relief control for the Water-machine series and fixes a few small glitches. Uses version 1.08 software

**A24** Minor fixes from A23 include enabling the Start/stop button to halt the system in ALL modes of operation, and to display when the tanks are full when the system has shut down if applicable. Software for A24 is version **1.08**, upgrading to A24 is a microprocessor change.

**A23** is a test revision firmware. Features added include voltage cutoff spread increase, rotor-flow operation, Auto-fill mode, and some display improvements. A23 is quite functional but a few improvements have been made to make the system more user friendly. Software for A23 is version **1.06**. Upgrading to A23 is a microprocessor change.

**A21** was the standard working firmware for a while, no-frills solid working code. Some problems that might be encountered with A21 are that the high and low voltage cutoffs are not spread out far enough– you are more likely to see high and low voltage alarm problems because of it. Software for A21 is version **1.03**. Upgrading from A21 to A23 is a microprocessor change.

**A19 to A21** in 12 and 24 volt systems requires a minor wiring change. The fresh water flush module for A19 was run with an external timer relay which is now incorporated into the firmware for A21 and beyond. The fresh water flush module shared a ground connection with the motor control relay. The process to upgrade is as follows:

Locate the Motor Control cable, a 2 conductor 18gauge cable. The white lead in this cable is connected to “PMP2” on the circuit board. The BLACK lead of this cable is unioned with the white lead of the fresh water flush cable. DISCONNECT the black lead of the motor control cable, strip the insulation and crimp a ring lug on it, and connect it to the “GND” next to “PMP2”. Next locate that white wire from the Fresh Water Flush cable, and cut it back to nothing, it is no longer used.

On the other end of the Fresh Water Flush cable, disconnect all wires from the timer relay. You may discard the timer relay. Cut away the white lead of the Fresh Water Flush cable. Then connect the black and red leads to the leads of the fresh water flush solenoid (they are either both black or both white- it does not matter which goes to which). Secure the connections with either butt connectors or a terminal block.

A new A21 or A23 microprocessor is also necessary when upgrading from A19, as now we do not have a timer for our fresh water flush module. Also don't forget to upgrade your computer software to 1.03 or 1.06, respectively. Be certain the pump On and Off times in the computer settings match with the needs of your system.

Upgrading an A19 1000gal/Monterey/AC system to A21/A23 requires only a new microprocessor- no wiring changes are necessary.

### A19 Spectra.ini file:

It has been found that during some installations of the Spectra A19 software, the Spectra.ini file is written incorrectly, resulting in a half display when the spectra software is run.

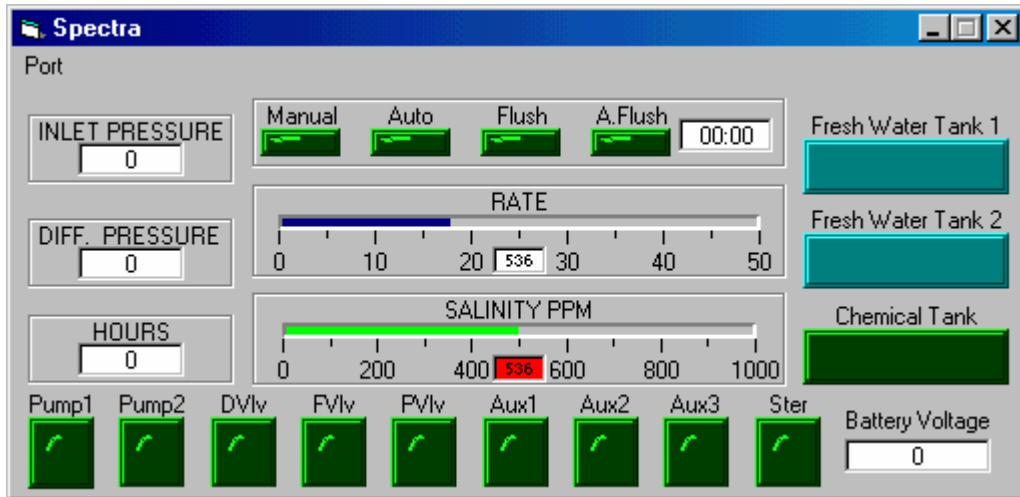

Notice that all the computer settings, such as Max Pressure and Displacement are missing from the screen.

To remedy this, open your Spectra.ini file using notepad or other text editing software. The spectra.ini file looks like this:

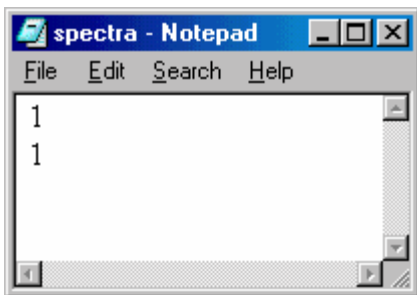

The first number, in this case '1', would be the COM port that your computer will use to connect to the MPC board. You can change this manually from here if you wish to, or it can be changed via the Spectra software.

The second number is what we're concerned with; a '1' in this field will give you the half display. Change this number to '2', save and close Spectra.ini, and run Spectra.exe; the display will return to normal.

## Prefilter Notes:

At some point around mid 2002 it was realized that the silkscreen on the PCB for the prefilter “inlet” and “outlet” connections was wrong. A number of systems went out with the cables reversed. To test this, remove one of the cables at the pressure sensor and start the system. If the system stops and you get a “CHECK PREFILTER” alarm then the cable that is still connected should be located at the inlet side. If the system continues to run, then the cable that is connected is the outlet cable and should be located on the outlet side of the filter port.

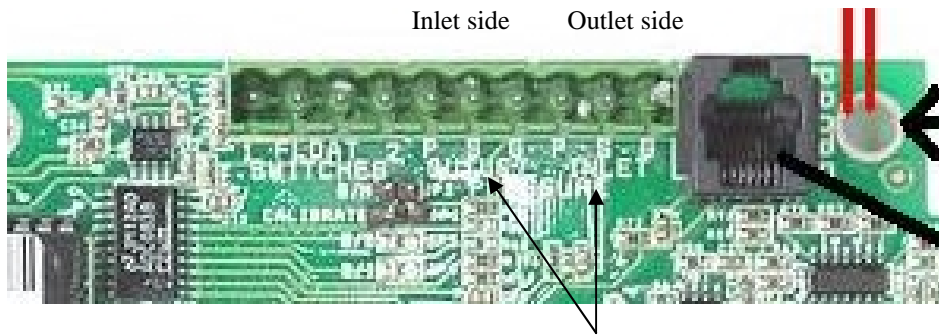

Notice silkscreen is reversed



## Tank Switch Operation:

The MPC controller can be set up to use your tank switches in two ways. For normal operation (using either Manual Run mode or Auto Run mode) simply connect the switches to the Tank1 and Tank2 connections on the MPC board. If only one switch is to be used, connect a jumper across the unused tank connection. Note that the switch must be installed in a position that will cause it to close (short) when the tank is full.

In Manual or Auto Run mode, the system will stop producing water when both tank switches are closed, perform a fresh water flush, and shut down.

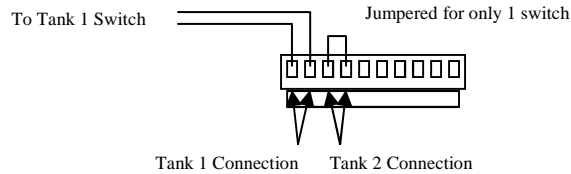

The second way to use tank switches is by using Auto Fill mode. This mode has been specifically designed to work with tank switches to provide continuous unattended operation of the water-maker system.

In this mode, two tank switches are installed in a single tank; one for a 'minimum' water level and one for a 'maximum' water level. Both switches should be positioned to close, or 'short' when the water level reaches the switch, and open when the water is below the switch.

## How it Works:

Press and hold the "Auto Run" button for 5 seconds– the display will read "AUTO FILL MODE". The system will begin operation and produce water, filling the tank. Eventually the water level will rise until it reaches the "maximum" switch– at this time, the display will read "TANK/S FULL"; the system will at this point stop producing water, perform a fresh water flush, and then go into a 5-day flush cycle storage mode. The display will cycle "TANK/S FULL" and "FLUSH TIMER INTERVAL", indicating the time remaining until the next flush occurs.

As you use the water in your tank, the water level will drop until it reaches the "minimum" switch– at this time the system will 'wake up' out of storage mode, sensing that the minimum tank level has been reached, and will begin to produce water again until the water reaches maximum.

It is possible to use this mode with only one tank switch– some connections will need to be made to 'trick' the unit into thinking it has two switches. See diagram below. Install the single switch at the maximum level, and jumper the Tank1 A&B connections to the Tank2 A&B connections accordingly. Note that in doing this, the system will produce water any time the water level in the tank drops below maximum.

Tank1 = MAX  
Tank2 = MIN

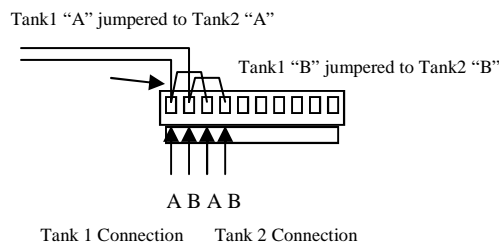

# **Spectra MPC-3000**

## **Operation Guide**

Newport Mode A

This document is a basic outline of MPC-3000 mode operations. It details what is seen on the LCD display, what outputs are active during run-time, and how the different modes work together.

Newport Mode A is the basic Newport 400 12 or 24 volt DC system. With the jumper at JP2 installed.

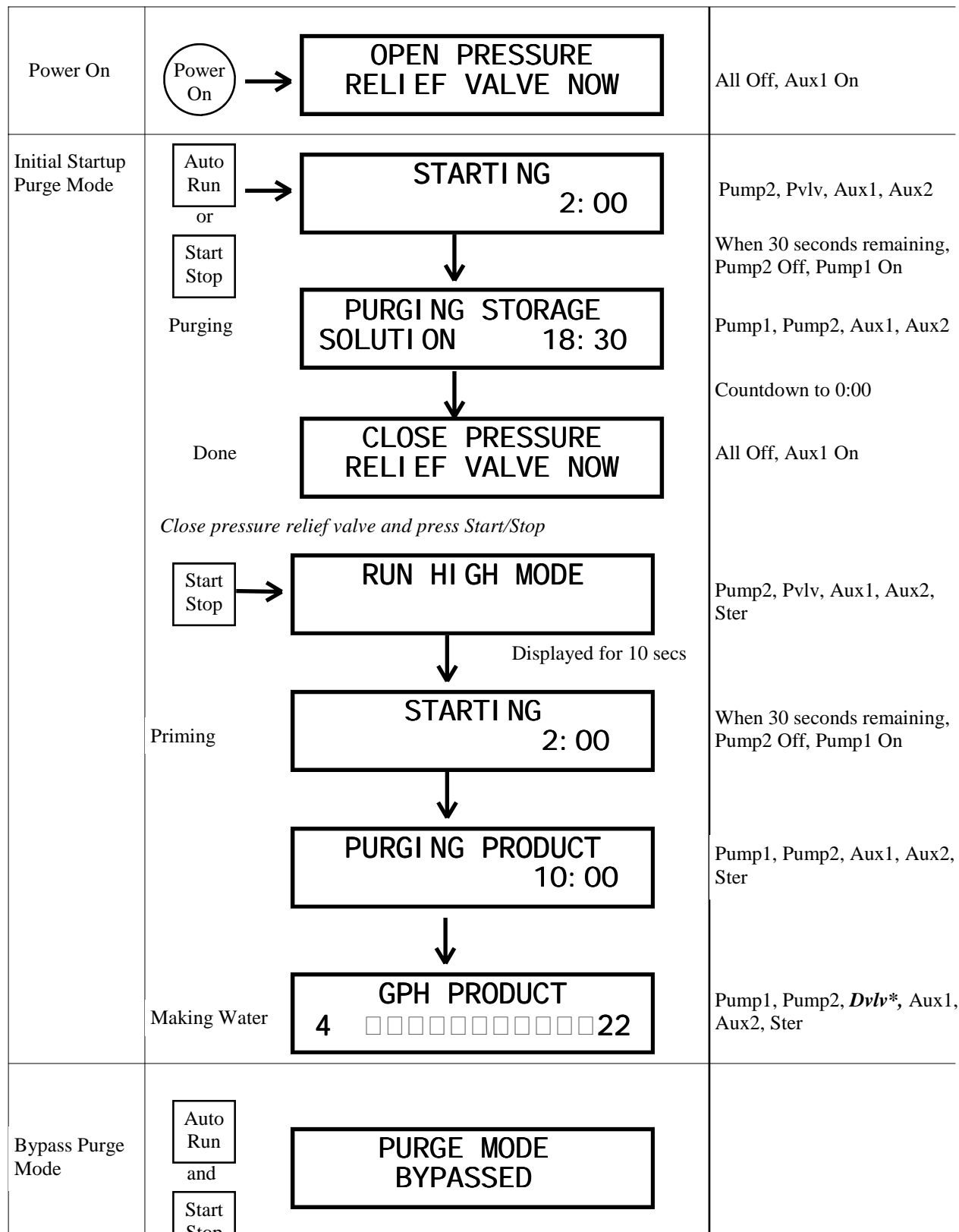

Simultaneously

Manual Run Mode

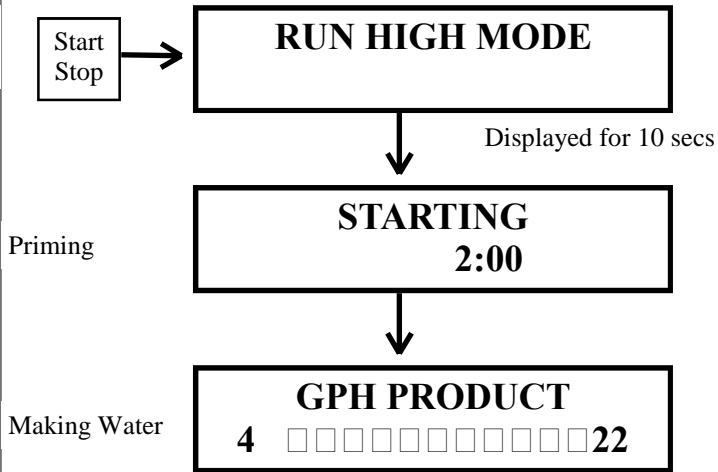

Pump2, Pvlv, Aux1, Aux2, Ster

Priming

When 30 seconds remaining, Pump2 Off, Pump1 On

Making Water

Pump1, Pump2, *Dvlv\**, Aux1, Aux2, Ster

*\*Note on Diversion Valve Operation: During a water making mode, a 60 second salinity check is performed; If salinity is within tolerance (<500ppm) for a continuous 60 seconds, the Diversion valve will open, and the “good” LED will be lit.*

*If salinity is out of tolerance, the Diversion valve will close, and the “reject” LED will be lit. Salinity must drop below tolerance and remain within tolerance for a continuous 60 seconds before Diversion valve will open.*

Low Mode

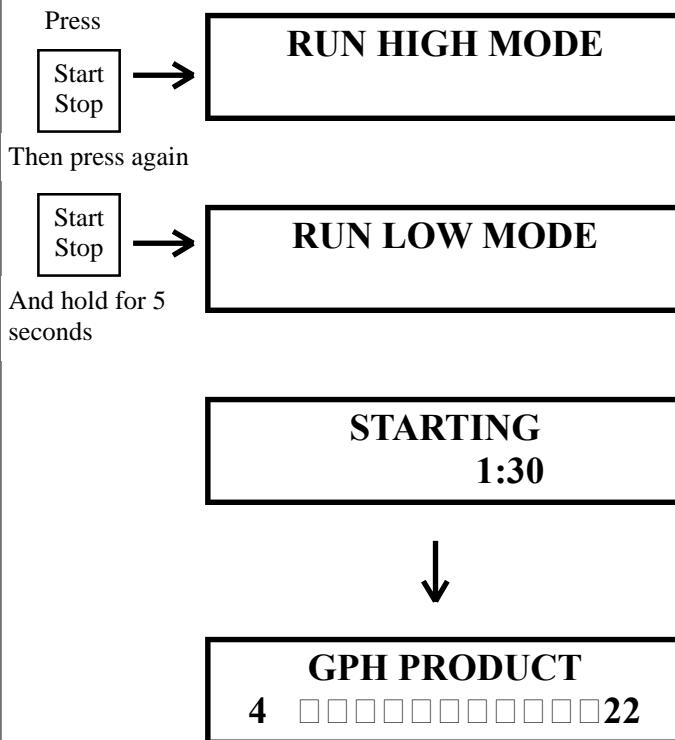

Pump2, Pvlv, Aux1, Aux2, Ster

When 30 seconds remaining, Pump2 Off, Pump1 On

Pump1, *Dvlv\**, Aux1, Aux2, Ster

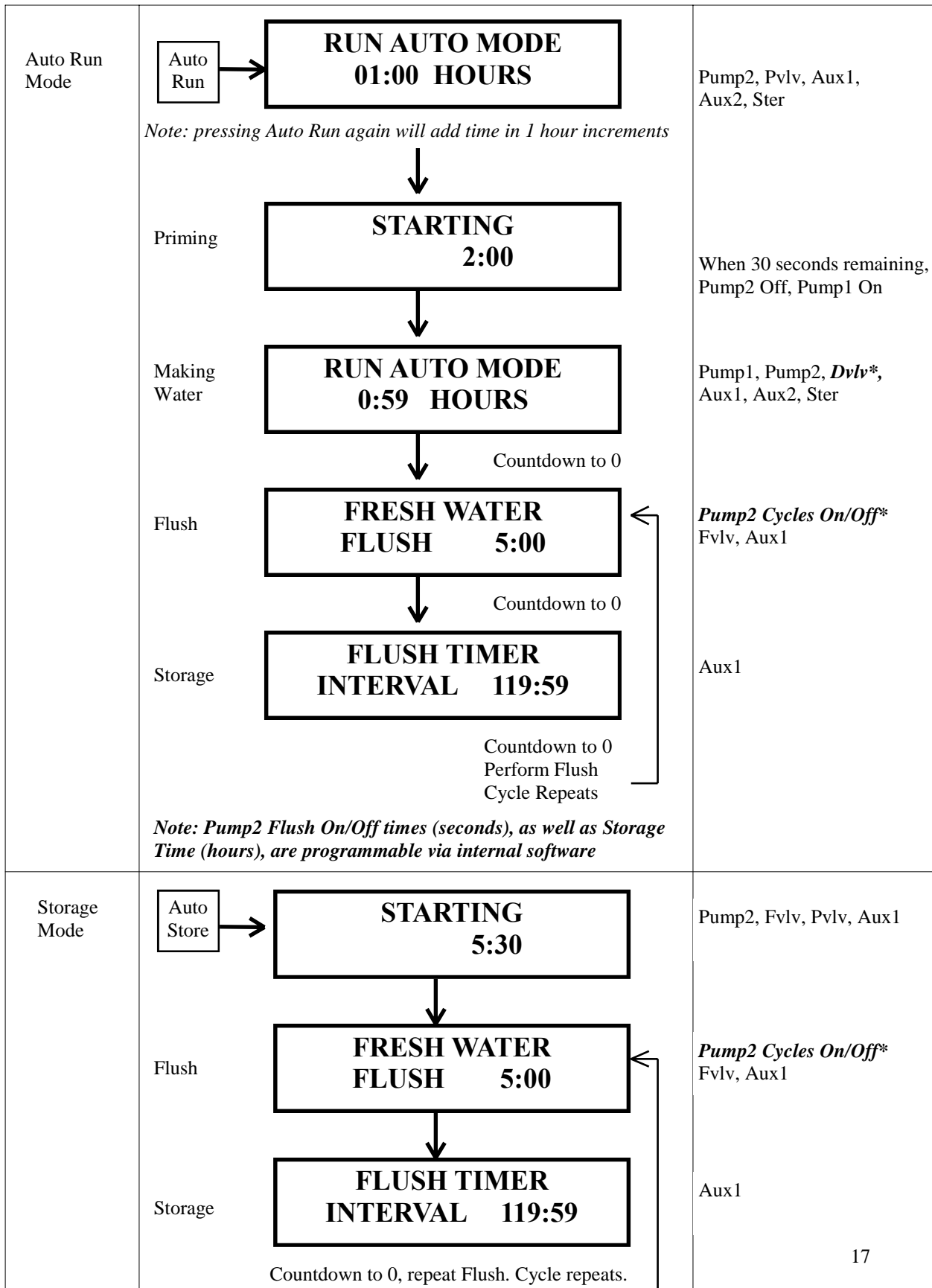

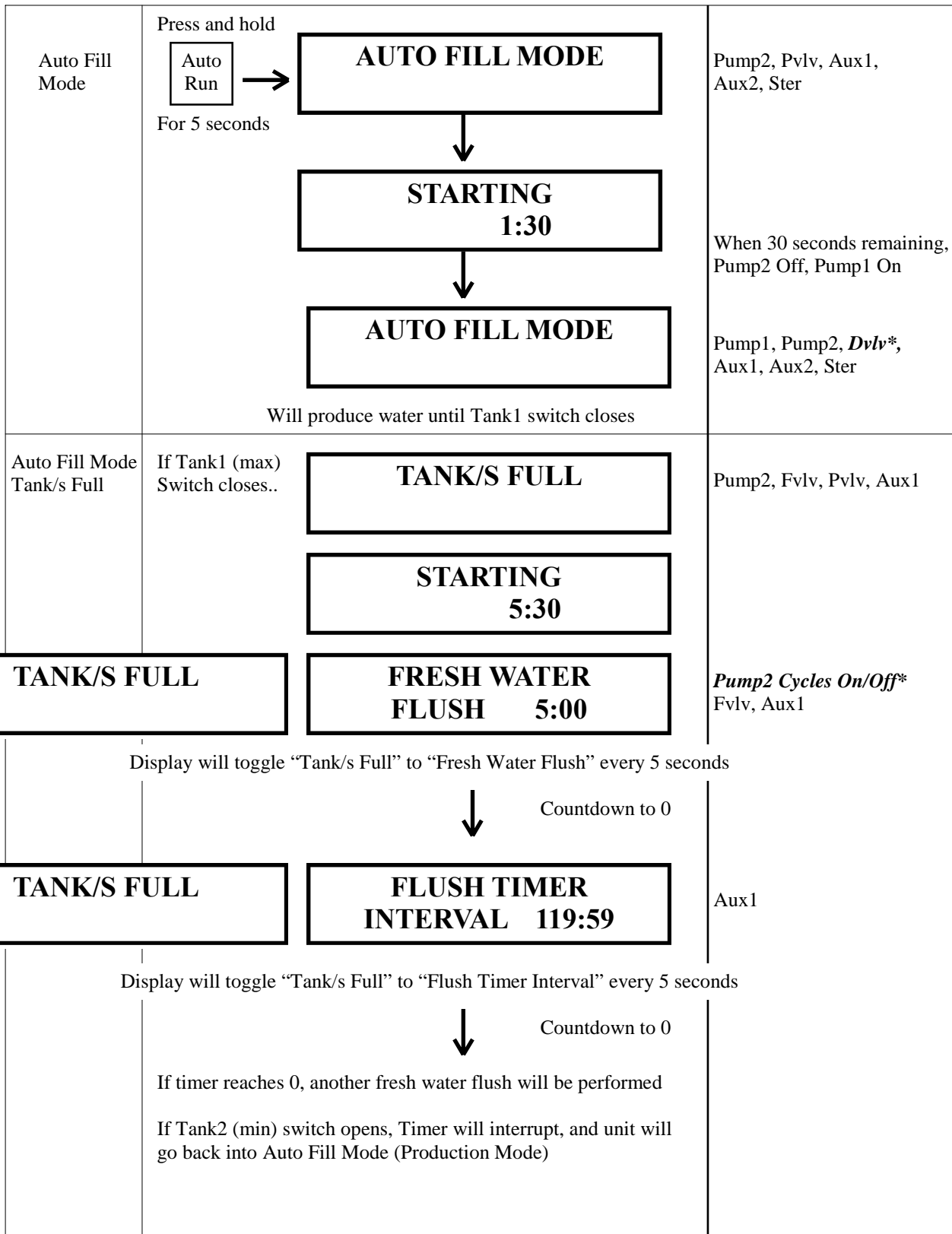

Run-time  
Readouts

Alarm  
Disp

Pressing Alarm/Disp at any time  
during run cycle will cycle  
through the following readouts:

Push and hold

Alarm  
Disp

Converts to Metric

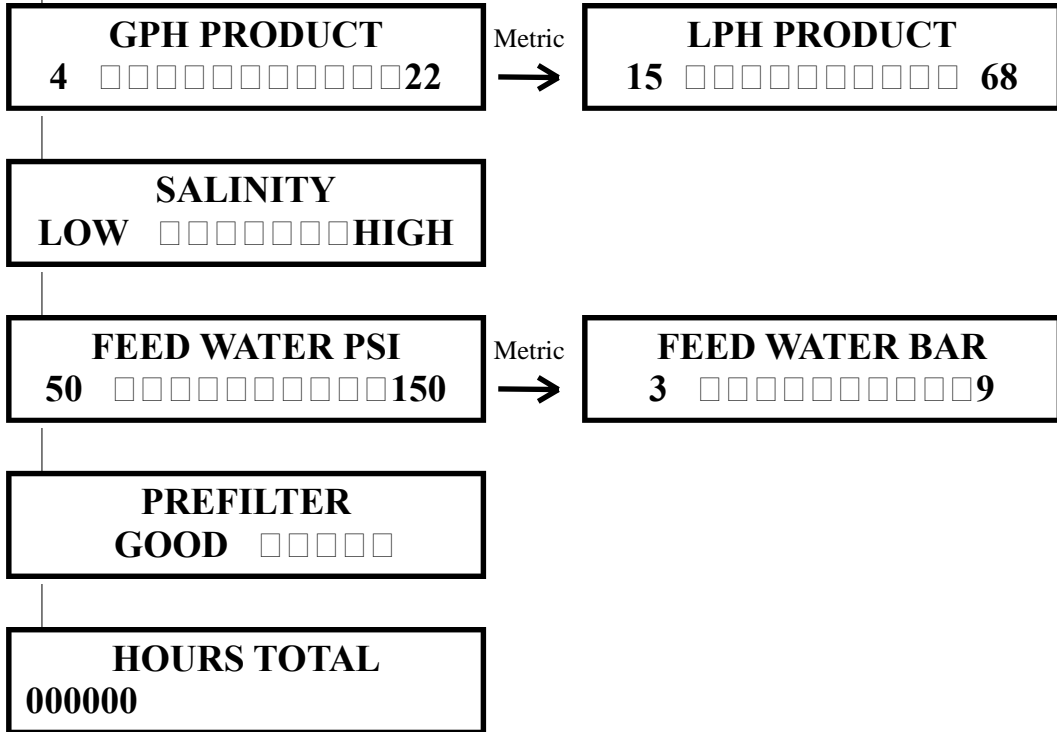

<p>If Inlet Pressure &gt; Max Pressure (150psi for Newport Systems)</p> <div style="border: 2px solid black; padding: 10px; text-align: center; width: fit-content; margin: 0 auto;"> <b>HIGH PRESSURE</b> </div>	<p>Shutdown, Audible Alarm Alarm LED lit</p>
<p>If Stroke not sensed for 30 seconds:</p> <div style="border: 2px solid black; padding: 10px; text-align: center; width: fit-content; margin: 0 auto;"> <b>RE-STARTING 2:00</b> </div> <p style="text-align: center;">↓ Countdown to 0, retry previous mode</p> <p>If still no stroke</p> <div style="border: 2px solid black; padding: 10px; text-align: center; width: fit-content; margin: 0 auto;"> <b>RE-STARTING 2:00</b> </div> <p style="text-align: center;">↓ Countdown to 0, retry previous mode</p> <p>If still no stroke</p> <div style="border: 2px solid black; padding: 10px; text-align: center; width: fit-content; margin: 0 auto;"> <b>SYSTEM STALLED</b> </div>	<p>Pump1 Off, Pump2 On</p> <p>Pump1 Off, Pump2 On</p> <p>Shutdown, Audible Alarm Alarm LED lit</p>
<p>If no Inlet; 10" of vacuum sensed at vacuum switch:</p> <p>Error Occurred</p> <div style="border: 2px solid black; padding: 10px; text-align: center; width: fit-content; margin: 0 auto;"> <b>CK SEA STRAINER</b> </div> <p style="text-align: center;">↓ Begin FWF Mode</p> <p>Fresh Water Flush</p> <div style="border: 2px solid black; padding: 10px; text-align: center; width: fit-content; margin: 0 auto;"> <b>FRESH WATER FLUSH 5:00</b> </div> <p style="text-align: center;">↓ Countdown to 0</p> <p>Shutdown</p> <div style="border: 2px solid black; padding: 10px; text-align: center; width: fit-content; margin: 0 auto;"> <b>CK SEA STRAINER</b> </div>	<p>Audible Alarm, Alarm LED lit</p> <p>If problem corrects itself, Audible alarm off</p> <p>FWF Mode: Pump2 cycles On/Off, Fvlv, Aux1</p> <p>Shutdown, Audible Alarm Alarm LED lit</p>

<p>If DC Input voltage too low:</p> <div style="border: 2px solid black; padding: 10px; text-align: center; width: fit-content; margin: 10px auto;"> <b>VOLTAGE TOO LOW</b> </div>	<p>Begin FWF Mode To Shutdown</p>
<p>If DC input voltage too high:</p> <div style="border: 2px solid black; padding: 10px; text-align: center; width: fit-content; margin: 10px auto;"> <b>VOLTAGE TOO HIGH</b> </div>	<p>Begin FWF Mode To Shutdown</p>
<p>If salinity probe bad or disconnected:</p> <div style="border: 2px solid black; padding: 10px; text-align: center; width: fit-content; margin: 10px auto;"> <b>SALINITY PROBE FAILED</b> </div>	<p>Shutdown</p>
<p>If blown fuse</p> <div style="border: 2px solid black; padding: 10px; text-align: center; width: fit-content; margin: 10px auto;"> <b>CHECK FUSE X</b> </div> <p style="text-align: center;">(Where 'x' represents number of blown fuse (1-5))</p>	<p>Shutdown</p>
<p>If Tank1 or Tank2 switch closed for 2 minutes:</p> <p style="margin-left: 40px;">No display, software registers that Tank1 or Tank2 is full.</p> <p>If Tank1 AND Tank2 switch closed for 2 minutes:</p> <div style="border: 2px solid black; padding: 10px; text-align: center; width: fit-content; margin: 10px auto;"> <b>TANK/S FULL</b> </div> <p>Depending on operating mode, system may at this point begin a fresh water flush, begin storage mode, or shut down. Refer to Operating Modes.</p>	

If salinity above tolerance:

Reject lamp lit, 20 minute internal counter begins

Dvlv Off

If salinity above tolerance for 20 minutes::

**SALINITY HIGH  
FLUSH 5:00**

Begin FWF Mode  
Audible Alarm  
Alarm LED lit

Shutdown

**SALINITY HIGH**

Aux1

# **Spectra MPC-3000**

## **Operation Guide**

Monterey Mode B

This document is a basic outline of MPC-3000 mode operations. It details what is seen on the LCD display, what outputs are active during run-time, and how the different modes work together.

Monterey Mode B is the Monterey or Newport 1000 gallon AC or DC system, with the jumper at JP2 removed. There are slight differences in output activity between this mode and the regular Newport 400 mode.

Care should be taken to insure that the proper mode has been selected.



*\* Monterey Mode B Only- Jumper at JP2 Removed \**

